

IBIS CYCLES

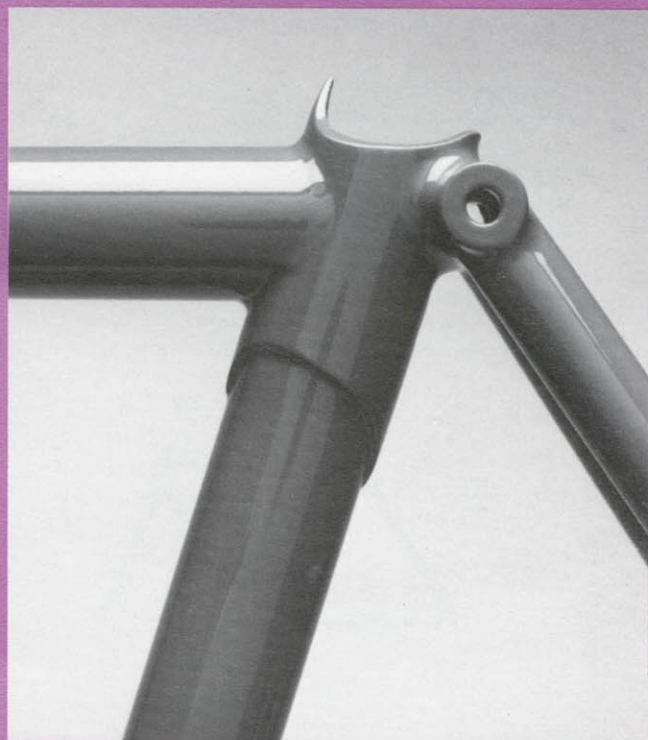
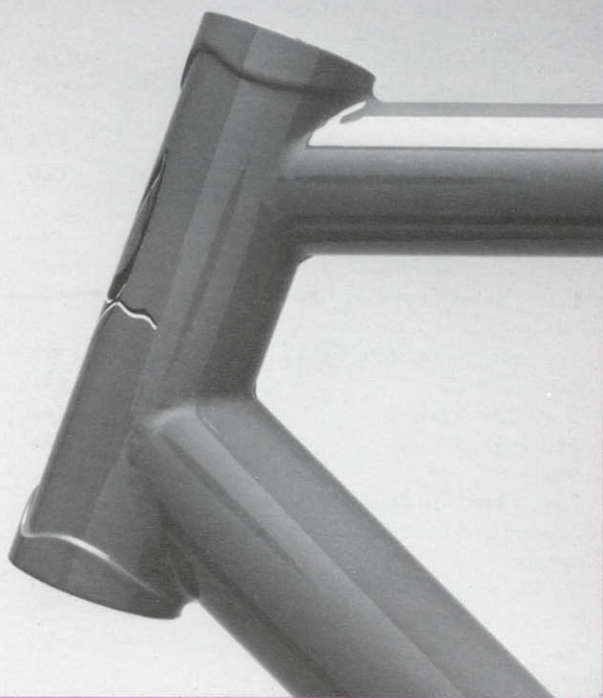

CUSTOM

The custom bikes we build provide the backbone for our company. IBIS started in 1981. People liked what they saw, liked what they bought. We are now one of the most respected names in the bicycle business. The priority at IBIS is to build the bike that is best suited to the customer. We specialize in fitting bicycles to people, not people to bicycles. We make it the way you want it, striving throughout to balance the most important ingredients in a well made bicycle.

◀ **DURABLE and LIGHT** ▶ Balancing these qualities involves selecting tubing with thickness, diameter and butting appropriate to the rider's weight and riding demands. Responsible framebuilding begins with the most important component — the rider. Beyond our frames, IBIS balances strength and weight by selecting and blending from a range of components, once again to best suit the rider's style and riding environment.

◀ **CUSTOM FIT** ▶ Using your measurements the bike is designed to be optimally suited to your body and riding preference. Our custom frame, fork and stem will work together to put you in the most comfortable and efficient riding position.

◀ **PRECISE HANDLING** ▶ We build beautifully balanced machines for virtually any riding

situation. Responsiveness, quickness and stability have evolved from thousands of miles of testing, selecting from many different approaches to frame geometry.

◀ **CONSTRUCTION** ▶ We have chosen a combination of TIG welding and brazing as the preferred method of assembly. The front triangle on our bikes are TIG'ed while the rear is brazed. The result is minimum weight and expense with superior strength and beauty.

◀ **PAINT** ▶ The final touch on the custom IBIS is the paint. We are well known for our wild and innovative schemes. There are a world of possibilities out there, let us help you with your ideas. We do long and short fades, splatters, spirals, patterns, stripes and much more. Of course you may also opt for the "standard" paint, which is your choice of any Imron color, with a glossy clear coat applied over the decals.

The custom IBIS is a beautiful machine. Beauty to us is our TIG welded joints, stronger and less expensive to produce than a brazed joint. Beauty to us is our custom paint, providing the customer with countless options. Beauty is the package as a whole; the design, the building, the finished product. We build our bikes to be ridden and enjoyed.

IBIS CUSTOM

IBIS BICYCLE PRICES

Complete Bicycle	\$1699
Frameset (frame, fork, stem)	\$899

IBIS FRAMESET

IBIS Custom frame, fork
 IBIS Upright or L.D. (drop bar) stem
 Silca pump painted to match
 2 sets water bottle bosses
 Complete brake & derailleur fittings
 Choice of any single IMRON color

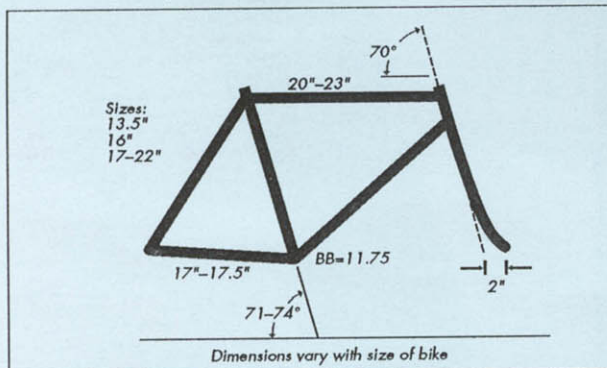

IBIS COMPONENTS

Freewheel:	Suntour XC 9000
Crankset:	Suntour XC 9000
Chainrings:	XC 9000 28-38-48 round
Pedals:	Suntour XC Compe
Chain:	Suntour XC 9000
Rims:	Specialized GX-23
Tires:	Ground Controls/Kevlar
Hubs:	Suntour XC 9000
Spokes:	WheelSmith SS 14g
Rear brake:	Suntour XC 9000 S.E.
Front brake:	Suntour XC 9000
Brake levers:	Suntour XC 9000
Handlebars:	Salsa chromoly
Seatpost:	Suntour XC
Headset:	Specialized Steel
Saddle:	Selle Italia Turbo
Grips:	Grab-On

FRAME OPTIONS (add to standard price)

Additional water bottle mounts	+15
Rear rack mounts	+22
Low-Rider rack mounts	+35
Shoulder strap and braze-ons	+29
Remove eyelets on dropouts (each)	+22
Additional colors (each)	+50
Color matching (we match your sample)	+40
Long fades between colors	+135
Splatter paint	+43
Total Custom IBIS paint	quote
Plated chainstay, dropouts	+245

COMPONENT OPTIONS

(add to standard price)

COMPONENT GROUPS

Shimano Deore XT-II	quote
Campagnolo Centaur	quote
Forks	
IBIS Type II	+215
IBIS Koski bladed (straight)	+120
Hubs	
Shimano Deore XT-II	n/c
WTB GreaseGuard 36 hole	+155
WTB GreaseGuard 32 hole	+160
Rims	
Specialized GX-26 or GX-22	n/c
Araya RM-20	+20
Bontrager MA-2	+15
Bontrager MA-40	+50
Tires	
Specialized Fat Boys (slicks)	n/c
Specialized Crossroads II or Hardpack	n/c
Brakes	
Shimano Deore XT-II canti or U brake	n/c
Pederson SE	+28
WTB Speedmaster, front or rear, each	+170
Brake Levers	
Shimano Deore XT-II	n/c
DiaCompe AGC (drop)	n/c
DiaCompe Tech 5 (2 finger)	
Bars	
Nitto DirtDrops (heat treated)	+37
Ibis Heat treated drops	+37
Shifters	
Shimano Deore XT-II	n/c
Shimano or Suntour indexed bar cons	+22
Rear Derailleurs	
Shimano Deore XT-II	n/c
Shimano 105 short cage	n/c
Front Derailleurs	
Shimano Deore XT-II	n/c
Cranksets	
Shimano Deore XT-II	n/c
Cook Bros	+107
Pedals	
Shimano Deore XT-II comp	20
Suntour XC-9010	+35
Headsets	
Specialized alloy	+16
Specialized Black alloy	+23
Chris King sealed bearing	+62
WTB/King GreaseGuard	+129
Seatposts	
IRD	+60
Saddles	
Specialized Blob	n/c

Deposits are required on all Custom orders. We require \$500 on complete bikes, \$300 on framesets. Shipped UPS unless otherwise specified. Prices are subject to change without notice.

Cambria Bicycle 1920 Main St Cambria CA 93428
805-927-5510

IBIS CYCLES



AVION & CUSTOM AVION

◀ **AVION** ▶ The Ibis Avion was the first production bike available from us. The ever increasing demand for our custom bikes convinced us it was time for a less expensive model, hence the Avion. The root of the word Avion is from the Latin "to Fly." We feel the name is an accurate representation of the bike's capabilities.

Our 16" Avion has 26" wheels front and rear, a shorter top tube, steeper seat angle and special small stem, all designed to accommodate the smaller person. Geometry comes from our experience building custom bikes. In each size range we evaluated the dimensions of the customers and the bikes we built for them. That information was "plugged" into a formula similar to the custom and the result was the Avion. The Ibis geometry tends towards a shorter top tube length than what is currently in fashion. The designers at Ibis see the bike as a balanced machine rather than a few isolated dimensions.

◀ **CUSTOM AVION** ▶ One of the many unique products offered by Ibis is the Custom Avion. The Custom Avion frame is built in Japan, finished and painted at our factory in Sebastopol. We install the braze-ons here, so you get what you want. We finish and align it here, so we know it's right. We paint it so you get it how you ask for it. Ibis is able to offer this service because we are a full service frame shop, not just a distributor. Since we keep these bikes in stock, the turnaround time is fast, 7-10 days. In under 2 weeks, you can have a bike with a paint job designed by you, and the braze-ons exactly how you want them. The closest thing to a custom bike at a production price.

The components are among the finest available anywhere. Shimano Deore XT-II (with Hyperglide) throughout, Tange double butted CrMo mountain bike tubing, our curved rake "fat fork," Tioga T-Bone stem available in a variety of lengths, Alloy Bulge handlebars, 32 hole Specialized X-23 rims, Vetta gel saddle, and Ground Control Tires round out the quality components found on this machine.

IBIS AVION

BASE PRICES

(complete bicycle w/std components)

Avion S	1070.
Deore XT-II/Hyperglide, stock colors	
Avion X	1095.
Deore XT, any paint/braze-ons	
Avion XH	1175.
Deore XT-II/Hyperglide, any paint/braze-ons	
Avion Frameset	565.
Frame, fork, and stem, any paint/braze-ons	

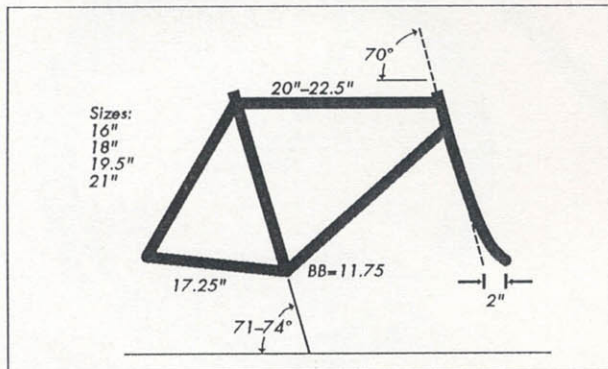

OPTIONS

(add to base price)

Type II IBIS fork	+215.
Koski fork (IBIS manufactured straight blades)	+120.
Cantilever rear brake	+22.
Rear rack mounts	+22.
Low-Rider mounts	+29.
Additional water bottle mounts	+15.
Shoulder strap (19.5" & 21" only)	+24.
Remove standard fittings (each)	+8.
Silca frame fit pump (painted to match)	+17.
Custom Upright IBIS stem (painted to match)	+79.
Salsa roller stem (painted to match)	+79.
Other component options	quote

PAINT

(available on X, XH and framesets only)

Additional colors (each)	+50.
Color matching (we match your sample)	+40.
Custom splatter paint	+43.
Short fade between colors	no extra charge
Long fade between colors	+135.
Total Custom IBIS paint	quote

AVION S or XH COMPONENTS

Freewheel:	XT II HyperGlide 12-28
Crankset:	Deore XT
Chainrings:	Biopace 26-36-46
Pedals:	Deore XT Comp
Chain:	Hyperglide
Rims:	Specialized X-23 32°
Tires:	Ground Control
Hubs:	Deore XT-II HyperGlide 32°
Rear brake:	Deore XT-II cantilever
Front brake:	Deore XT-II cantilever
Brake levers:	Deore XT-II 2 Finger
Handlebars:	Tioga Bulge
Seatpost:	Strong
Headset:	Tioga MTB Master
Saddle:	Vetta Gel

AVION X COMPONENTS

Freewheel:	Deore XT Cassette 12-28
Crankset:	Deore XT
Chainrings:	Biopace 26-36-46
Pedals:	Deore XT
Chain:	Uniglide
Rims:	Araya RM-20 Hard Ano 36°
Tires:	IRC X-1 Pro
Hubs:	Deore XT Freehub 36°
Rear brake:	XT cantilever or U brake
Front brake:	Deore XT cantilever
Brake levers:	Deore XT
Handlebars:	Tange Prestige Bulge
Seatpost:	Strong
Headset:	Deore XT
Saddle:	Avocet Touring 1

The IBIS Avion is a Japanese bicycle produced to our specifications. It provides the well-known handling characteristics of the IBIS Custom bicycle at a significantly lower price. The IBIS Avion is available in 3 configurations, or as a frameset. The S is supplied with standard paint and components, and is usually available for immediate shipment. The X and XH are supplied with the paint and braze-ons of your choice. They are finished and painted here at our frameshop in the USA to the same standards as our custom bicycles, and are usually shipped within one week of receipt of your order. You may purchase the frameset only, with the braze-ons and paint of your choice.

Prices are subject to change without notice. All orders will be shipped U.P.S. unless otherwise specified.

Cambria Bicycle 1920 Main St Cambria CA 93428
805-927-5510

IBIS CYCLES



AVION S.S.

The newest model in the Avion lineup is the Avion S.S. The S.S. is made in our Sebastopol, Ca. factory. One of the many great things about building the Avion S.S. in our own facility is that it gives us the option to give you options. You decide the paint. You decide your braze-ons. Need component substitutions? We can provide. We install the braze-ons here, so you get what you want. We build, finish and align it here, so we know it's right. We paint it so you get it how you ask for it. IBIS is able to offer this service because we are a full service frame shop, not just a distributor. Since we keep these bikes in stock, the turnaround time is fast, 7-10 days. In under 2 weeks, you can have a bike with a paint job designed by you, with the components (including stem sizing) you want, and the braze-ons exactly how you want them. The closest thing to a custom bike at a production price. Look at the order form. Look at the options available. Think about the possibilities.

Our 14" Avion has 26" wheels front and rear, a shorter top tube, steeper seat angle and special small stem, all designed to accommodate the smaller person. Geometry

comes from our experience building custom bikes. In each size range we evaluated the dimensions of the customers and the bikes we built for them, then created the optimal geometry of the Avion S.S.

All of the tubes on this bike are bigger than the average bike. The top tube and seat tube are 1 $\frac{1}{4}$ ". The seat post is our exclusive 29.4mm. It's long, but it's not slender. The down tube is 1 $\frac{3}{8}$ ", for a torsionally stiff (i.e. precise) front end. The lightweight taper gauge blades of the Koski fork smooths out the bumps and the large tip diameter keeps the oscillation and deflection under heavy braking to a minimum. The components are among the finest available. Suntour XCD components, True Temper triple and double butted CrMo mountain bike tubing, Koski Unicrown fork, Salsa stem available in a variety of lengths, Salsa handlebars, 32 hole Araya RM-17 rims, Vetta gel saddle, and Ground Control Tires round out the quality components found on this machine. You also have the option of three other component groups if you care to upgrade. Campagnolo Centaur, Suntour XC-9000 and Shimano Deore XT STI are available.

IBIS AVION S.S.

IBIS BICYCLE PRICES

Complete Bicycle	\$1150.
Frameset (frame, fork, stem)	\$650.

IBIS FRAMESET

IBIS Avion S.S. frame
 Koski unicrown fork
 Salsa Upright stem
 2 sets water bottle bosses
 Complete brake & derailleur fittings
 Choice of Turquoise, Red, or Graphite paint

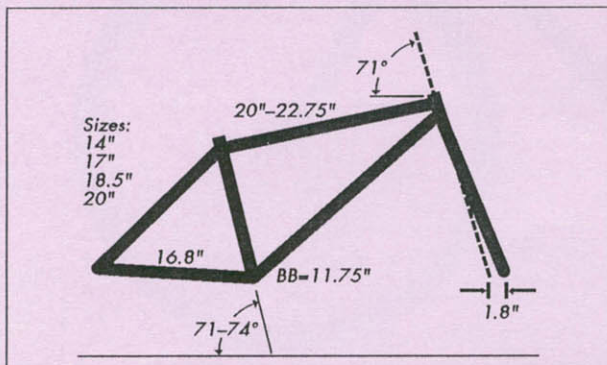

STANDARD COMPONENTS

Freewheel:	Suntour XCD 6000
Crankset:	Suntour XCD 6000
Chainrings:	XCD 6000 28-38-48 round
Pedals:	Suntour New XCD
Chain:	Suntour
Rims:	Araya RM-17
Tires:	Specialized Ground Control
Hubs:	Suntour XCD 6000
Rear brake:	Suntour XCD 6000 Cantilever
Front brake:	Suntour XCD 6000 Cantilever
Brake levers:	Suntour XCE
Handlebars:	Salsa chromoly
Seatpost:	Strong 29.4mm
Headset:	Specialized steel
Saddle:	Vetta Gel

FRAME OPTIONS (add to standard price)

Additional water bottle mounts	+15.
Rear rack mounts	+22.
Low-Rider rack mounts	+35.
Shoulder strap and braze-ons	+29.
Remove eyelets on dropouts (each)	+22.
Additional colors (each)	+50.
Colors other than standard (see above)	+55.
Long fades between colors	+135.
Splatter paint	+43.
Total Custom IBIS paint	quote

COMPONENT OPTIONS

add the listed cost to the base price of the bike

COMPONENT GROUPS

Suntour XC-9000 (includes XC-Compe pedals)	+300
Shimano Deore XT-II	+325
Campagnolo Centaur	quote
Forks	
IBIS Type II	+215
Stem	
IBIS custom upright	+79
IBIS Custom L.D. (for drop bars)	+99
Hubs	
WTB GreaseGuard 36 hole	+225
WTB GreaseGuard 32 hole	+235
Rims	
Specialized GX-26	+45
Araya RM-20	+45
Bontrager MA-2	+54
Bontrager MA-40	+64
Tires	
Specialized Crossroads II or Hardpack	+28
Specialized Ground Control "S"	+38
Brakes	
Pederson SE	+57
WTB Speedmaster, front or rear, each	+160
Brake Levers	
DiaCompe AGC (drop)	+22
Dia Compe Tech 5	+15
Bars (L.D. stem recommended with Drop bars)	
DirtDrops	+38
Ibis Heat treated drop bars	+38
Shifters	
Shimano or Suntour indexed bar end	+43
Cranksets	
Cook Bros	+135
Pedals	
Suntour XC-9010	+65
Headsets	
Specialized alloy	+31
Specialized Black alloy	+35
Chris King (sealed bearing)	+90
Seatposts	
IRD	+50
Suntour XC	+35
Saddles	
Specialized Blob	+21
Turbo	+30

All prices FOB. Sebastopol. Orders will be shipped U.P.S. unless arranged otherwise. Prices are subject to change without notice.

Cambria Bicycle 1920 Main St Cambria CA 93428
805-927-5510

IBIS CYCLES



MT. TRIALS

The Mt. Trials is a refreshing new change in the mountain bike world. The Mt. Trials is capable of taking your riding skills to a new level of expertise. This bike will do what you tell it to. Whether you ride mainly on the road (this is the criterium bike of mountain bikes), on rough trails, singletrack, slickrock or fireroads, the IBS Mt. Trials is the funnest, most responsive bike you could choose for the task at hand. Now the Mt. Trials is available as a production bike, which gives it a new lower price tag.

Don't let the name fool you. The Mt. Trials is a mountain bike, not a trials bike. Although originally designed as a bike for trials competition, the Mt. Trials has become our favorite all around bike. (We've ridden this bike to three top ten finishes in the Pro class at the NORBA Trials Nationals.) We've ridden it in the rain forests of the Pacific Northwest (log hop central). We've hopped around in our front yard (the neighbors think we're weird, but they're glad we haven't ridden over their cars). We've had the maximum dose of fun on the slickrock - any more fun would probably be illegal - and we've

ridden it on the longest mountain bike rides, with a few log and rock long cuts thrown in just to make the other riders jealous.

The Mt. Trials is shorter and steeper than other mountain bikes. the front wheel is 26", the rear 24" (there are now several good 24" tires to choose from). The chainstays are 15". The top tube is 22.75". Tie this to a 72° headtube angle with 1.5" of rake and you have one responsive ride. It comes in 2 sizes, 13.5", to accommodate riders up to 5'8", and 17" to accommodate riders taller than that. All of the tubes on this bike are bigger than the average bike. As our ads say, **"This is no SKINNY PUPPY."** The top tube and seat tube are 1 1/4". The seat post is a grandé 29.4mm. The down tube is 1 3/8", for a torsionally stiff (i.e. precise) front end. Tandem gauge oval unicrown with straight blades complete the fastidious front end design. We offer a milled outer chainring (which acts as a rock protector) as an option in case you want to use this bike as a hybrid trials and mountain bike. This is the year to step up, to "Chuck Your Slug," and opt for the sport bike of the year.

IBIS MT. TRIALS

Complete Bicycle Price:

\$895

The Mt. Trials is not available as a frameset at this time.

MT TRIALS COMPONENTS

Freewheel:	Shimano Deore Cassette 12-28
Crankset:	Shimano Deore
Chainrings:	26-38 Biopace
Outer Chainring:	44t or milled outer "rock" ring
Deraileurs:	Shimano 105
Shift Levers:	Shimano Deore
Pedals:	Shimano Deore
Chain:	Shimano Uniglide
Rims:	Specialized X-26
Tires:	Specialized Ground Control
Hubs:	Shimano Deore Freehub
Spokes:	Stainless Steel 14g
Rear Brake:	Shimano Deore U-II
Front Brake:	Shimano Deore II Cantilever
Brake Levers:	Shimano Deore II 4 Finger
Handlebars:	Tioga alloy bulge
Seatpost:	Strong 29.4 mm oversize
Headset:	Tioga MTB Master
Saddle:	Vetta Gel
Stem:	Tioga T-Bone

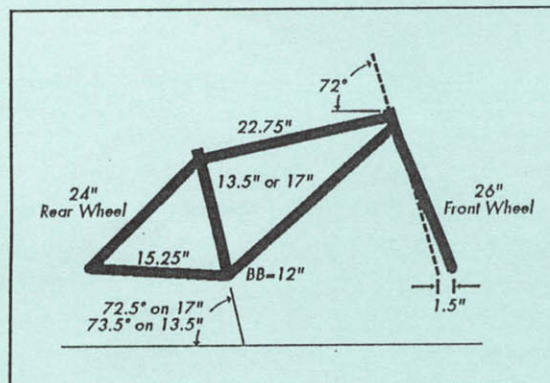

Mt. Trials Geometry

**Cambria Bicycle 1920 Main St Cambria CA 93428
805-927-5510**

IBIS CYCLES



TRIALS COMP

The popular Ibis Trials Comp was introduced two years ago. It is a no nonsense competition trials bike at an entry level price. We didn't cut any corners when we made the Comp. Design features include a CrMo custom frame and fork, special Ibis trials stem and handlebar, full CrMo T.I.G. welded construction, trials tires, cast alloy bash guard, and cranks. See reverse side for specifications and geometry — the same geometry which Ibis rider Andy Grayson rode to the 1988 National Championship in the NORBA Pro class.

Our first trials bike was built 5 years ago. 26" wheels, a high bottom bracket, short wheelbase and chainstays, and upright geometry were its features. It worked well. We then changed things around a bit and put a 24" rear wheel on it. It worked even better. Several incarnations later we felt pretty good about this bike. We did the Nationals on it. Then people started hopping and everything changed. The 20" rear wheel came next, along with 24" in the front. The 20" wheel is stronger, lighter, and provides better traction than larger wheels. It also stays out of the way in those extremely tight situations. The larger front wheel tracks

better through the rough, and also provides superior control when coming off large obstacles. Although the top Europeans and Americans do use a 20" front wheel, we feel that unless you're one of the top riders in the country, a 24" front wheel is better, for the above mentioned reasons. Our rider Andy Grayson didn't switch to a 20" wheel until he was among the top 3 riders in the country. The bottom bracket may seem low for a trials bike (12"), but the extremely short wheelbase makes the "effective" B.B. much higher. Riding a trials bike can work wonders for your skill on a regular mountain bike. Learn to hop in place, to lift the front wheel, the back wheel, both wheels. It can only help. Then go try it on your mountain bike. You'll be surprised at how easy it is, and how your confidence on the bike is enhanced. You'll probably notice how much fun you're having. Whether you're competing in one of the many Trials events held all over the country, trying a little urban trials on the stairs at the local courthouse (look out, they might arrest you for having too much fun), or just playing around in your back yard, the Trials Comp will provide you with endless amusement and challenge.

IBIS TRIALS COMP

Complete Bicycle Price (includes bash guard) \$449
 Frame only \$110
 There are no Trials Comp forks or bash guards available at this time

TRIALS COMP COMPONENTS

Stem	Ibis designed CrMo steel with hanger
Freewheel:	Suntour 18t
Crankset:	Sugino trials 165 mm
Chainring:	24 t
Derailleurs:	Dere ain't none
Shift Levers:	No shifters neither
Pedals:	Victor VP-456
Chain:	KMC
Rims:	Araya 7X Silver Alloy
Tires:	IRC Trials Winner
Hubs:	Joy Tech Alloy
Spokes:	Stainless Steel 14g
Rear Brake:	Shimano Deore U
Front Brake:	Shimano Deore U
Brake Levers:	Lee Chi 2 Finger
Handlebars:	Custom Bent Ibis Cr Mo Trials
Seatpost:	Cr Mo
Headset:	Tange steel
Saddle:	Small, light, uncomfortable plastic unit
Bash Guard:	Cast Alloy (Mike Augspurger design)

Also available: Jim Ellis' (Back Country Bicycles East) Trials Comp makeover.
 includes: Increased Braking power (through booster plates and lever modification), plus numerous details to fine tune the performance of this machine. Call B.C.B.E. for details.

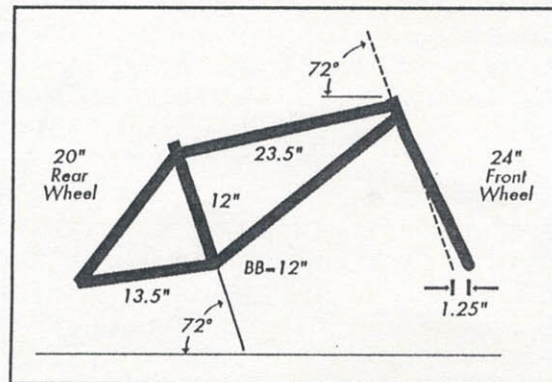

Trials Comp Geometry

**Cambria Bicycle 1920 Main St Cambria CA 93428
 805-927-5510**

IBIS CYCLES



COUSIN IT

The success of our original tandem inspired the creation of the Cousin It. The painstaking detail required to build our Uptube™ tandem necessitates its high price. The Cousin It is the result of an effort to build a tandem with the performance capabilities of the Uptube™ machine, at a more affordable price.

The first thing you may notice about the Cousin It is the lack of an uptube. Since the Uptube™ is the heart of the responsive performance of the original tandem, and a genuine pain to build a bike with, the task at hand was to create a machine that could almost match its ride performance, but without an Uptube™. This was accomplished in part by using oversize tubing throughout on this bike. It has 1¼" seat tubes with 29.4mm oversize seat posts. The top and diagonal tubes are 1⅜". As on all of our bikes, the wheels are the strong and light 26" mountain bike standard.

The bike is constructed of a combination of CrMo airframe tubing and True Temper CrMo tubing, TIG welded together. We make the forks with tandem gauge Tange Oval Unicrown blades and our own "bomber" steerer. The steerer is 1" dimension so there will be no compatibility prob-

lems with any oddball sizing. Both front and rear stems are constructed specifically for the tandem, and available in a variety of sizes. Like the stems for our custom bikes, they are TIG welded Chrome Moly.

The dialed in geometry is the same as on our other Tandem. There are 3 sizes to choose from. 20.5/19 for the big people, 19/17 for a good chunk of the population, and for you members of the sub 5'5" club, the 17/15. The ability to successfully change riders of different heights is made possible by the use of the oversize seatposts. The oversize posts are strong and stiff, even with a lot of the post hanging out.

We have chosen components that have proven their reliability to us. Rather than using components from any one manufacturer, we select the best possible components for the job. Specifications are on the reverse. The bike comes with either drop or upright handlebars, attesting to its versatile nature as a true hybrid. With a simple change of handlebars and tires you can transform this bike from a terror on the road to a fun playbike if you need to get away from the pavement. (Hot Tip: By far the funnest day I ever spent on the Slickrock was on a Cousin It tandem—they are made for each other.—Ed)

IBIS "COUSIN IT"

IBIS "COUSIN IT" TANDEM PRICES

Complete Tandem (Base Price)	\$2499
Frameset only	\$1650

IBIS TANDEM FRAMESET INCLUDES

IBIS Tandem frame-direct lateral design
 IBIS Tandem fork. Oval bladed Tandem unicrown
 IBIS stems, upright or drop bar
 7 sets water bottle bosses
 Complete brake & derailleur fittings
 Stock colors Black, Turquoise, Red or Graphite

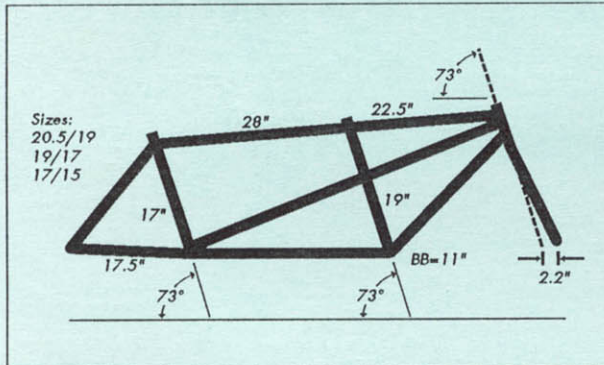

COMPLETE TANDEM STD COMPONENTS

Freewheel:	Deore XT 12-28 6 speed
Crankset:	Specialized
Chainrings:	28-38-48
Derailleurs:	Deore XT
Shift levers:	Deore XT
Pedals:	Deore XT
Chain:	Shimano UniGlide
Rims:	Araya RM-20 Super hard 36°
Tires:	IRC X-1 Pro
Hubs:	Shimano Deore XT 36°
Spokes:	Stainless Steel 14g
Rear brake:	Deore XT U Brake
Front brake:	Deore XT cantilever
Brake levers:	Deore XT
Handlebars:	Salsa chromoly Bulge
Seatpost:	Strong oversize 29.4 mm
Headset:	Specialized steel
Saddles:	Avocet Touring I
Stoker Stem	Ibis (4.25" or 5.75" reach)

FRAME OPTIONS (add to standard price)

Adjustable Stoker Stem	+100
Additional water bottle mounts (each set)	+15
Rear rack mounts	+15
Low-Rider rack/front fender mounts	+30
Additional rear Brake mount	+22
Drum Brake Braze ons (included in drum kit)	+30
Paint other than standard colors	+70
Additional colors (each)	+50
Long fades between colors	+135
Splatter paint	+50
Total Custom IBIS paint	quote

COMPONENT OPTIONS

Add these prices to the complete bicycle price.

Hubs

Phil Wood	+110
WTB	+215
Specialized 40°	+100

Rims

Specialized GX-26 40° (with Drum kit only)	+55
--	-----

Tires

Specialized Fat Boys (slicks)	+28
Specialized Hardpack	+30
Specialized Ground Control	+30
Ground Control S	+40

Brakes

Pedersen S.E. Brakes	+70
Rear Deore XT-II Cantilevers	+30
WTB Speedmaster, front or rear, each	+185
Suntour XC-9000 self energizing (rear)	+30

Brake Levers

Suntour XC	+28
Shimano XT-II 2 finger	+35
DiaCompe AGC (drop-2 pair)	+40

Bars

Specialized Mod 1 (drop bar), each	+10
Nitto DirtDrops (heat treated), each	+35
Ibis Heat Treated drop bars, each	+35

Shifters

Shimano or Suntour indexed bar end	+49
------------------------------------	-----

Rear Derailleurs

Suntour XC 9010 Accushift	+12
---------------------------	-----

Front Derailleurs

Suntour XC 9010	+17
-----------------	-----

Cranksets

Cook Bros	+175
Chainring sizes your choice	+40

Pedals

Suntour XC Compe	+70
Suntour XC9010	+120
Shimano clipless (Ultegra)	+180
Shimano clipless (Dura Ace)	+290

Saddles

Specialized Blob, each	+18
Turbo, each	+22

Drum Brake Kit

36 or 40 hole double thread rear hub	+185
Arai Alloy drum brake, mounted	
Thumb or bar end shifter for control	
All necessary braze ons	

Deposits are required on all Tandem orders. We require \$1000. on complete tandems, \$500. on framesets. Tandems shipped by Truck unless otherwise specified. Prices are subject to change without notice.

Cambria Bicycle 1920 Main St Cambria CA 93428
805-927-5510

IBIS CYCLES



TANDEM

◀ **Tango Uptube™ Design** ▶ Conventional wisdom was thrown out the window when it came time to design the IBIS Tandem. Our approach is different, and works phenomenally well. The IBIS Tandem has 26" wheels. It also has an Uptube™, which runs from the front B.B. to the rear seat cluster. The Uptube™ is the brainchild of Rick Jorgensen, designer and builder of Tango Tandems. The Uptube™ allows us to increase the rear top tube length, increasing stoker comfort, and provides increased rigidity even with the acres of room provided the stoker. Some of the tubes are round, some are oval. It comes with upright and/or drop bars and a beautiful chromed adjustable stem in the rear. The components are the best available. If there isn't an adequate component out there, we'll manufacture it. The seat tubes are 1¼". The seatposts are our monster 30mm models. The large diameter seatpost makes the sizing a breeze. The combination of the oval Uptube™ and top tube, together with the oversize rear seatpost all but eliminates the flag pole effect (we call it stoker lag) that is evident on other more flexible tandems. This is the tendency for the seatpost to flex

laterally in a turn, as if you were sitting on a flagpole, resulting in a disconcerting and potentially dangerous ride.

Our tandems are the most versatile tandems made. They're equally at home in the dirt or on the street. We've personally done camping tours in Europe, Baja, New Zealand and at home here in the States.

Although we plunged into mountain bikes head first, it would be a hard call to assess which we embraced with a greater passion, tandems or mountain bikes. We've impressed people with the amazing handling capabilities on dirt or slickrock, towed 30 people up and down the hills on our local club rides (especially centuries), and simply – and most importantly – ridden with our partners sporting ear to ear grins. The IBIS Tandem spells fun. If you haven't had the pleasure of the tandem experience yet, you owe yourself a treat. Try one out. Read what the experts say. Check out the road (and off road) test in the October '88 issue of *Bicycle Guide*. Or the Best of Cycling awards in the Feb. '89 *Bicycle Guide* where they decree "the IBIS Tandem is as good as it gets."

IBIS TANDEM

IBIS TANDEM PRICES

Complete Tandem (Base Price)	\$3699
Frameset only	\$2499

IBIS TANDEM FRAMESET INCLUDES

IBIS Tandem Uptube™ frame
 IBIS Tandem Type II fork
 IBIS Upright or LD (drop) stem, adjustable rear stoker
 8 sets water bottle bosses
 Complete brake & derailleur fittings
 Ibis seatposts (30 mm dia.)
 Drag brake braze ons

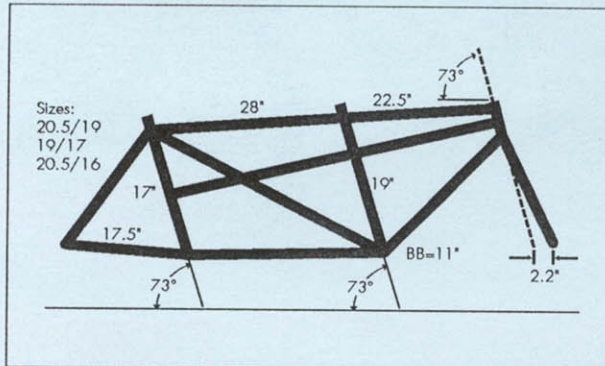

COMPLETE TANDEM STD COMPONENTS

Freewheel:	Suntour Winner Pro U7
Crankset:	Specialized
Chainrings:	30-44-54
Derailleurs:	Suntour 9010
Shift levers:	Suntour Barcons U7
Pedals:	Specialized road
Chain:	Suntour Pro
Rims:	GX-26 40°
Tires:	Fat Boys
Hubs:	WTB double threaded
Spokes:	Wheelsmith SS 14g
Rear brake:	Pederson SE U or Canti
Front brake:	Pederson SE cantilever
Brake levers:	Dia Compe AGC
Front Handlebar:	Nitto Heat Treated
Rear Handlebar:	Specialized Mod 1
Seatpost:	Custom IBIS 30.0 mm
Headset:	Specialized
Saddles:	Selle Italia Turbo

FRAME OPTIONS (add to standard price)

Additional water bottle mounts (each set)	+15
Rear rack mounts	+22
Low-Rider rack/front fender mounts	+40
Additional colors (each)	+50
Color matching (we match your sample)	+40
Long fades between colors	+135
Splatter paint	+43
Total Custom IBIS paint	quote
Plated chainstay, dropouts	+245

COMPONENT OPTIONS

Add these prices to the complete bicycle price.

Hubs

Phil Wood n/c

Rims

Specialized GX-22 or GX-23 36° n/c

Araya RM-20 36° n/c

Tires

Specialized Fat Boys (slicks) n/c

Specialized Crossroads II or Hardpacks n/c

Brakes

Deore XT brakes n/c

Suntour XC Sport rollercam, each n/c

WTB Speedmaster, front or rear, each +170

Arai Drum Brake (includes bar control) +50

Phil Wood disc (limited availability) +250

Brake Levers

Suntour XC n/c

DiaCompe AGC (drop) n/c

Bars

Nitto DirtDrops (heat treated), rear +28

Salsa Upright n/c

Rear Derailleurs

Shimano Deore XT n/c

Front Derailleurs

Shimano Deore XT n/c

Cranksets

Cook Bros +175

Chainring sizes your choice +23

Pedals

Suntour XC Compe +42

Suntour XC9010 +90

Shimano clipless (Ultegra) +180

Shimano clipless (Dura Ace) +290

Headsets

Specialized alloy +18

Specialized Black alloy +23

Chris King sealed cartridge bearing +85

WTB/King GreaseGuard +140

Saddles

Specialized BLOB, each n/c

Big Cookie Package

For large chainring greater than 54t +170

32/46/60t rings

Road Cranks with arms drilled for inner ring

Shimano Shift Package

Dura Ace freewheel 13-26 7 speed +135

Shimano Bar end shifters

XT rear derailleur

Dura Ace chain

Deposits are required on all Tandem orders. We require \$1000. on complete tandems, \$500. on framesets. Tandems shipped by Truck, others shipped UPS unless otherwise specified. Prices are subject to change without notice.

Cambria Bicycle 1920 Main St Cambria CA 93428
805-927-5510

IBIS CYCLES ▶ ETCETERA

◀ **FORKS** ▶ One of the most prevalent questions we get around here is what we think about the "new" straight bladed forks. The straight bladed Type II is in its 7th year of production here at IBIS.

You may notice that IBIS offers both straight and curved rake forks. Rather than fabricate a story that exposes our ignorance about bike design in general, and fork design specifically (believe it or not the two are related), we have chosen not to build all of the forks in our bike line the same (i.e. straight or curved). Each of our bike models is designed for a specific purpose, not just to hit a price point. You will notice that the Avion and our custom both come with a curved blade fork. But the Mt. Trials and Tandem have straight bladed forks. These bikes are designed for different purposes. Curved rake forks give you a slightly softer ride (that is if you keep all other factors such as rake, length, and tubing dimensions the same), while the straight bladed forks give you a less forgiving but more precise ride. They also damp shock better, which gives you more control.

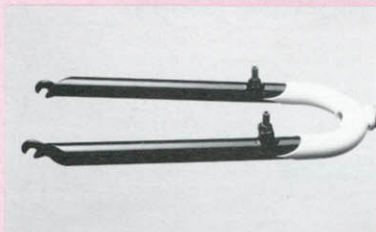

◀ **TYPE II FORK** ▶

IBIS started building the Type II fork in 1984. It has been our fork of choice for all of these years. Nothing has surpassed the ride characteristics of the Type II. Butted, non-tapered 1" blades (available in 3 different weights) are silvered into a 1 1/8" tubular CrMo crown. The 1" blades provide a shock damping and lateral stiffness unattainable by tapered forks. The ride is a bit more firm, but the added control in all situations is the overriding factor here.

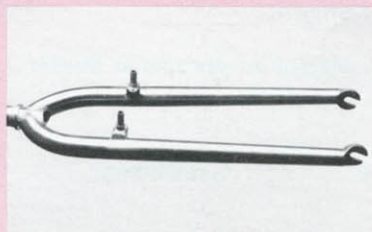

◀ **KOSKI FORK** ▶

IBIS manufactures this straight bladed fork from the Tange manufactured Koski designed CrMo tubing. This is the only fork that comes close to the performance characteristics of the Type II. It is slightly lighter, but not as strong. The Koski is slightly softer riding, but not as good at damping as the Type II. The Koski is one of the most highly regarded forks on the market today, and rightly so.



◀ **UPRIGHT BAR STEM** ▶

IBIS manufactures all of the stems that are equipped on our custom bikes. The stems are also available aftermarket in 12 sizes. See reverse side for the size chart. Constructed of TIG welded CrMo steel, we then braze on our own custom binders. Standard color is black, but the custom stems are available in any Imron color. The IBIS stem requires a sleeve out of the steerer. The stem is clamped to the sleeve. You have a choice of either having us braze one in, or you may install an expander which bolts into the steerer. The brazed in sleeve is lighter than having a quill welded to the stem extension piece. This system allows us to use our upright, drop bar or top secret Titanium stem.

◀ **DROP BARS AND DROP BAR STEM (MODEL L.D.)** ▶ Products that have been very popular both on our custom bikes and as an aftermarket item include our drop bar set-ups for mountain bikes. Our custom manufactured Model L.D. stem gets your drops where you need them for the most comfortable and efficient riding positions. Our L.D. stems are manufactured from 4130 tubing that's TIG welded into a functional yet pleasing configuration. Complementing the stem is the IBIS heat treated drop bar. The bar is thicker than a regular drop bar, and heat treated after bending to provide superior strength and longevity. The bar is bent 12.5° at the bottom for increased comfort and knee clearance. This bar/stem combination yields a steering system that gives you the flexibility in body position needed for climbing yet allows ultimate control on fast, bumpy descents. If you spend a lot of time in the saddle, drop bars may be the answer for you. We believe the bar end shifter is the best system available.

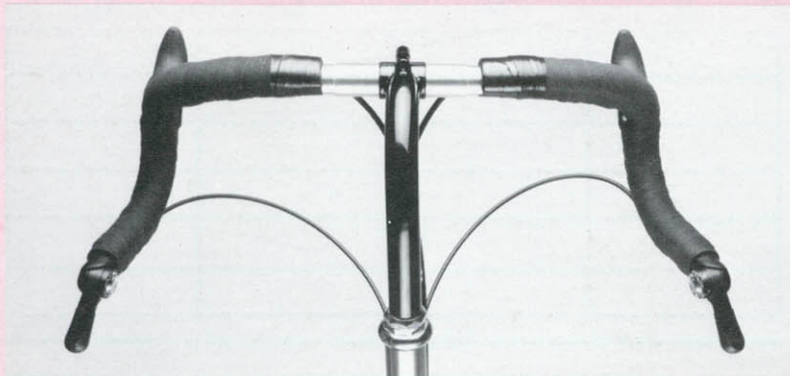

◀ **T-SHIRT** ▶ The IBIS T-Shirt is a stunning 6 color design beautifully printed on a 100% cotton heavyweight T. The design is abstract, but the graphic representation of the IBIS in flight is easy to see. The design has been a popular seller for several years now. One look at the design will tell you why. T-Shirts are available in short or long sleeve, with black available in the Long Sleeve version. Sizes are S, M, L, XL. (B&W half-tones don't do it justice, so you'll have to take our word for it or see it in person.)

Etc. Order Form

IBIS FORKS

Type (circle one): Type II Std unicrown Koski straight blade

Standard features: Rake: 1.8", Fork Length: 15.3", Cantilevers, Black. Please specify steerer length

Custom forks also available. Please specify:

Rake: _____ *Fork Length: _____ **Steering Tube Length: _____

*from Crown seat to axle center. Measured parallel to steerer

** (measured from crown seat to end of steerer)

Brake braze ons (circle one): Cantilever U-brake

Paint Instructions (Black is standard):

IBIS STEMS

Ibis Upright stem

extension

	3.5	4.0	4.5	5.0	5.5	6.0	6.5	
10 degree	n/a							Stem expander qty: _____
30 degree								

Ibis L.D. stem

Rise x Extension

4.5 x 2.5 4.5 x 3.5 5 x 3 5 x 4 6 x 3 6 x 3.5

--	--	--	--	--	--

Custom stem sizing also available. Indicate rise and extension. See price list for cost. All Ibis stems require a stem expander or a plug brazed into the steerer. All measurements in inches.

IBIS T-SHIRTS

	S	M	L	XL
Short sleeve 100% cotton (white)				
Long sleeve 100% cotton (white)				
Short sleeve 100% cotton (black)				
Crew Neck Sweatshirt (white)				
Hooded Pullover Sweat (white)				
Shop Apron (black, one size only)				

(REALLY IMPORTANT STUFF)

Shop Name _____ Order Date _____ Salesperson _____

**Cambria Bicycle 1920 Main St Cambria CA 93428
805-927-5510**

IBIS Price List

CUSTOM BICYCLES

Mountain Bike	\$1699
Tandem (Tango Uptube design)	3699
Cousin It Tandem (Production Tandem)	2499

CUSTOM FRAMESETS

Mountain Bike (includes stem and fork)	899
Tandem (Tango Uptube design)	2499
Tandem (New Ibis production Tandem)	1650

SEMI CUSTOM BICYCLES

Avion S.S. (USA made, Koski fork, Salsa stem)	1150
--	------

PRODUCTION BICYCLES

Trials Comp (2 colors available)	449
Mountain Trials (2 colors available)	895
Avion S (XT-II)	1050
Avion XH (XT-II, any pnt/braze-ons)	1175

IMPORTED FRAMESETS

Trials Comp (frame only)	115
Avion (frame, fork, stem, custom paint)	535

FORKS

IBIS Unicrown	160
IBIS Type II	300
IBIS with Koski DuraTrac straight blades	200

STEMS

IBIS stock Upright (12 sizes, black)	79
IBIS Custom Upright (custom sized, any color)	99
IBIS stock LD (drop) (6 sizes, black)	99
IBIS Custom LD (custom sizing, any color)	110
Steel expander (stub for IBIS stems)	20

BARS

Nitto heat-treated drop bars	55 50
Ibis heat treated drop bars	58 50

TRIALS EQUIPMENT

IRC 20" skinwall trials tires	24
IRC 24" skinwall trials tires	24

T-SHIRTS (white)

Short sleeve (100% cotton)	13
Long sleeve (100% cotton white or black)	15
Crew neck sweat	20
Hooded pullover sweat	30
Shop Apron (Black)	15

Deposits are required on all custom orders. We require \$1000. on tandems, \$500. on complete bicycles, and \$300. on framesets.

Tandems are shipped via truck, all other will be shipped UPS unless otherwise specified.

Prices are subject to change without notice.

**Cambria Bicycle 1920 Main St Cambria CA 93428
805-927-5510**